

All Pages Of This Edition Approved

Signature:

Date:

REV.	DESCRIPTION	REVISER	DATE
A0	First	luojinwei	2017-10-31

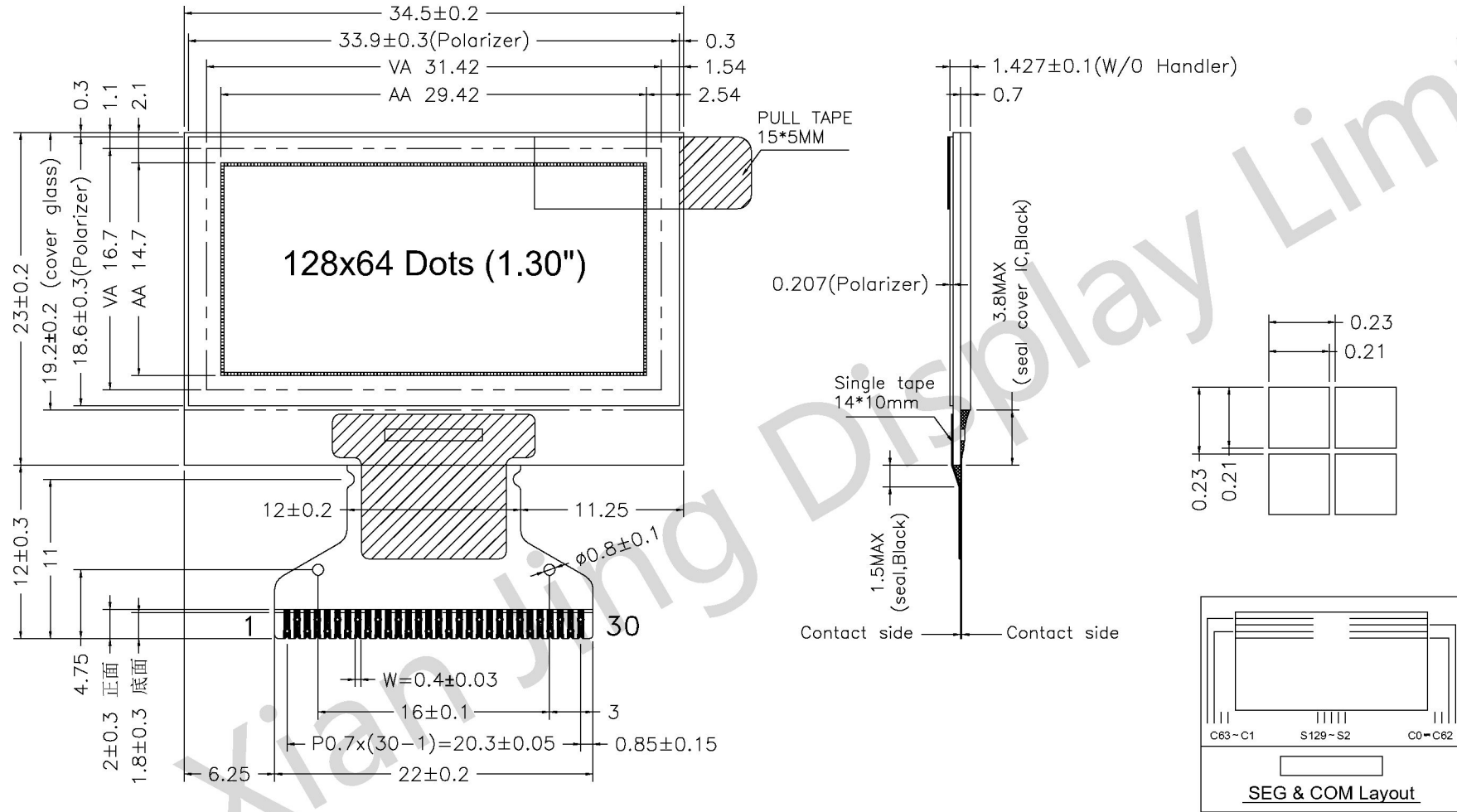

PIN	SYMBOL
1	NC(GND)
2	C2P
3	C2N
4	C1P
5	C1N
6	VBAT
7	VSS
8	VSS
9	VDD
10	BS0
11	BS1
12	BS2
13	CS#
14	RES#
15	D/C#
16	R/W#
17	E/RD#
18	D0
19	D1
20	D2
21	D3
22	D4
23	D5
24	D6
25	D7
26	IREF
27	VCOMH
28	VCC
29	NC
30	NC(GND)

Specifications:

1. Display : OLED(White).
2. Dot Matrix: 128*64
3. Dot Size: 0.21*0.21mm
4. Dot Pitch: 0.23*0.23mm
5. Aperture Rate: 83.3%
6. Active Area : 29.42*14.7mm
7. Drive IC: SH1106G
8. FPC P/N: FPC-HP12864-18-A0



深圳市华显晶显示技术有限公司

HUA XIAN JING Display Limited

www.huaxianjing.com

Unspecified Tolerance:	±0.20	UNITS: mm	DATE:	MODEL NUMBER :		SHEET:	1 OF 1
DESIGN BY:	luojinwei	2017-10-31	HP12864-18-KHWG30P130-A	SCALE:		1 : 1	
CHECKED BY:				DO NOT SCALE THIS DRAWING.	PROJECTION		
APPROVED BY:							