

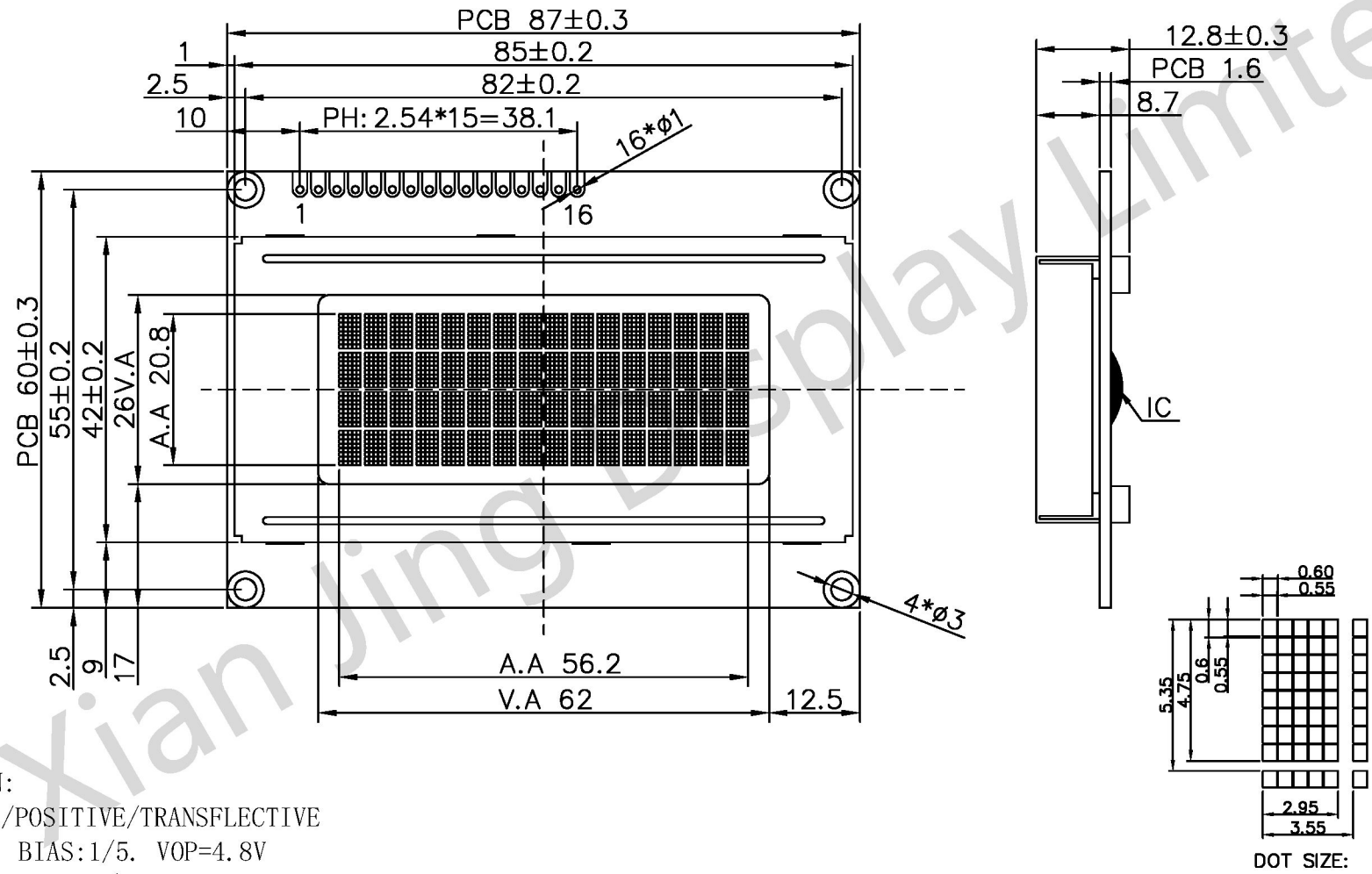

INTERFACE	
1	VSS
2	VDD(5V)
3	V0
4	RS
5	RW
6	E
7	DB0
8	DB1
9	DB2
10	DB3
11	DB4
12	DB5
13	DB6
14	DB7
15	LED-A(5V)
16	LED-K

VER	DETIAL DISCRPTION	DATE
00	FIRST ISSUE	2011-8-29



SPECIFICATION:

- 1). STN(GARY) /POSITIVE/TRANSFLECTIVE
- 2). DUTY:1/16. BIAS:1/5. VOP=4.8V
- 3). VIEWING ANGLE: 6 O' CLOCK
- 4). OPERATING TEMPERATURE: -20~70°C
STORAGE TEMPERATURE: -30~80°C
- 5). BACKLIGHT: WHITE I=40MA
- 6). DRIVE IC: AIP31066
- 7). DRIVE POWER: VDD=5.0V



深圳市华显晶显示技术有限公司

HUA XIAN JING Display Limited www.huaxianjing.com

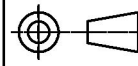
Unspecified Tolerance: ±0.20	UNITS: mm	DATE: 2011/8/29	MODE NUMBER: HSM1604B		SHEET: 1 of 1
DESIGN BY: WZQ	CHECKED BY:	CUSTOM NO:	DO NOT SCALE THIS DRAWING.		DATE: 2011/8/29